

### ATTENZIONE - ATTENTION - ACHTUNG

- Per lo smontaggio degli utensili utilizzare sempre la chiave di contrasto come indicato nel manuale d'uso.
- For disassembly of the tools use always the contrast key as mentioned in the user instructions.
- Fuer das Abmontieren der Werkzeuge immer den Gegenschlüssel benutzen wie in der Bedienungsanleitung erwäehnt.

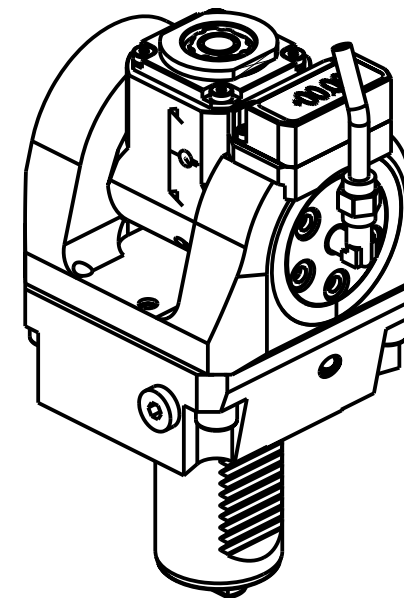

Cod. MT	Mandrino Spindle Spindel	I	RPM	Coppia Max Max Torque Max Drehmoment	Reversibile lato mandrino/contromandrino Reversible sub/main spindle side Umkehrbare Spindel-seite/ Gegenspindel-seite	Lubrificazione inf. Coolant through Innenkuehlung	Lubrificazione est. Ext. coolant Ausseinkuehlung	CHIAVI INCLUSE Keys included Schluessel inbegriffen		
TKW 1007316	ERA16	1:2	12000	8Nm	X	-	X	C HUB19_SP3	C HUB32	CHTAER16ZC
TKW 1007416	ERA16	1:2	12000	8Nm	X	P=70bar	X	C HUB19_SP3	C HUB32	CHTAER16ZC

TAKISAWA  
MOD: TMM200/250 - TNR200

MODULO MOTORIZZATO ORIENTABILE ±90° MOLTIPLICATO I=1:2 CON NONIO DIGITALE VDI40  
±90° adjustable angle driven tool geared-up I=1:2 with digital display VDI40  
Angetriebenes Werkzeug schwenkbar ±90° uebersetzt I=1:2 mit digital display VDI40

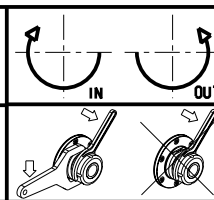

**M.T. srl**  
Via Casino Albini 480  
Tel. 0541/956034-957884  
Fax 0541/956341  
47842 S. GIOVANNI IN M. (RN)  
e-mail: mtma@mtmarchetti.com  
http://www.mtmarchetti.com



PAGINA TKW 336-3-01

Subject to change without notice.

09/2023