

-LA FUNZIONE DI POLIGONATURA/DENTATURA DEVE ESSERE INSTALLATA SULLA MACCHINA
 -POLYGON CUTTING/GEAR HOBBIING FUNCTION MUST BE INSTALLED ON THE MACHINE
 -DIE FUNKTION FÜR POLYGON-BZW. VERZÄHNUNGSFRÄSEN MUSS AUF DER MASCHINE FREIGESCHALTET WERDEN

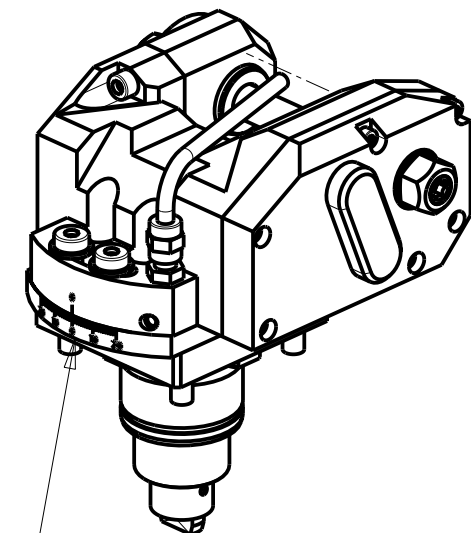

INCLINAZIONE REGOLABILE ±20°

Cod. MT	i	RPM max	Coppia Max Max Torque Max Drehmoment	Lubrificazione est. Ext. coolant Aussenkuehlung	D	CHIAVI INCLUSE Keys included Schlüssel inbegriffen				
DW 01611116	1:1	6000	30Nm	X	16	CHUB19	CHESL06	CHESL05	-	-
DW 01611113	1:1	6000	30Nm	X	13	CHUB19	CHESL06	CHESL05	-	-
DW 01611110	1:1	6000	30Nm	X	10	CHUB19	CHESL06	CHESL05	-	CHUB17
DW 01611108	1:1	6000	30Nm	X	8	CHUB19	CHESL06	CHESL05	CHESL04	CHUB13
DW 01611155	1:1	6000	30Nm	X	1/2"	CHUB19	CHESL06	CHESL05	-	-
DW 01612116	2:1	3000	50Nm	X	16	CHUB19	CHESL06	CHESL05	-	-
DW 01612113	2:1	3000	50Nm	X	13	CHUB19	CHESL06	CHESL05	-	-
DW 01612110	2:1	3000	50Nm	X	10	CHUB19	CHESL06	CHESL05	-	CHUB17
DW 01612108	2:1	3000	50Nm	X	8	CHUB19	CHESL06	CHESL05	CHESL04	CHUB13
DW 01612155	2:1	3000	50Nm	X	1/2"	CHUB19	CHESL06	CHESL05	-	-

HARD INGE
 MOD: T-42 16ST. - TALENT 42/51 12/16ST. - TALENT TT42/51 16ST. (BMT45)

MODULO MOTORIZZATO PORTACREATORE
 Driven gear hobber
 Angetriebenes Zahnradwaeltzraes-Werkzeug

Subject to change without notice.

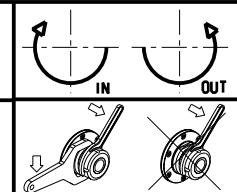

M.T. srl
 Via Casino Albini 480
 Tel. 0541/956034-957884
 Fax 0541/956341
 47842 S. GIOVANNI IN M. (RN)
 e-mail: mtma@mtmarchetti.com
 http://www.mtmarchetti.com



PAGINA HRD340-1-20