

ATTENZIONE - ATTENTION - ACHTUNG

- Con l'utensile orientato a 0° o 180°, non è possibile eseguire lavorazioni a centro-pezzo!
- It is not possible to make machining operations at the center of the part with tool oriented at 0° or at 180°.
- Mit einem Werkzeug um 0° oder 180° orientiert, ist es nicht möglich, Verarbeitung von der Werkzeug-Mitte auszuführen.

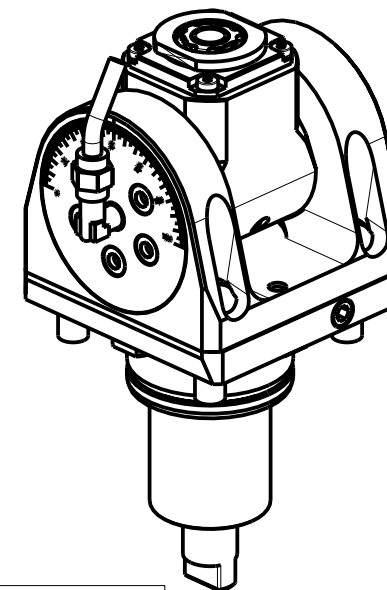

Cod. MT	Mandrino Spindle Spindel	I	RPM	Coppia Max Max Torque Max Drehmoment	Reversibile lato mandrino/contromandrino Reversible sub/main spindle side Umkehrbare Spindel-seite/ Gegenspindel-seite	Lubrificazione int. Coolant through Innenkuehlung	Lubrificazione est. Ext. coolant Aussenkuehlung	CHIAVI INCLUSE Keys included Schluessel inbegriffen			
								CHUB19_SP3	CHUB32	CHTAER16ZC	CHESL07
DW00660316	ERA16	1:2	12000	8Nm	X	-	X	CHUB19_SP3	CHUB32	CHTAER16ZC	CHESL07
DW00660416	ERA16	1:2	12000	8Nm	X	P=70bar	X	CHUB19_SP3	CHUB32	CHTAER16ZC	CHESL07

HARD INGE

MOD: T-51/65 12ST. (BMT55)

MODULO MOTORIZZATO ORIENTABILE +/-90° MOLTIPLICATO I=1:2 H=47.5mm

+/-90° adjustable angle driven tool geared-up I=1:2 H=47.5mm

Angetriebenes Werkzeug schwenkbar +/-90° uebersetzt I=1:2 H=47.5mm

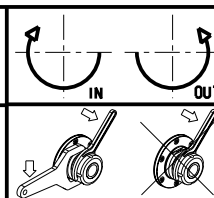

M.T. srl

Via Casino Albini 480
Tel. 0541/956034-957884
Fax 0541/956341

47842 S. GIOVANNI IN M. (RN)
e-mail: mtma@mtmarchetti.com
http://www.mtmarchetti.com



PAGINA HRD336-2-00

Subject to change without notice.

09/2023