

ATTENZIONE - ATTENTION - ACHTUNG

- Con l'utensile orientato a $\pm 90^\circ$, non è possibile eseguire lavorazioni a centro-pezzo!
- It is not possible to make machining operations at the center of the part with tool oriented at $\pm 90^\circ$
- Mit einem Werkzeug um $\pm 90^\circ$ orientiert, ist es nicht möglich, Verarbeitung von der Werkzeug-Mitte auszuführen.

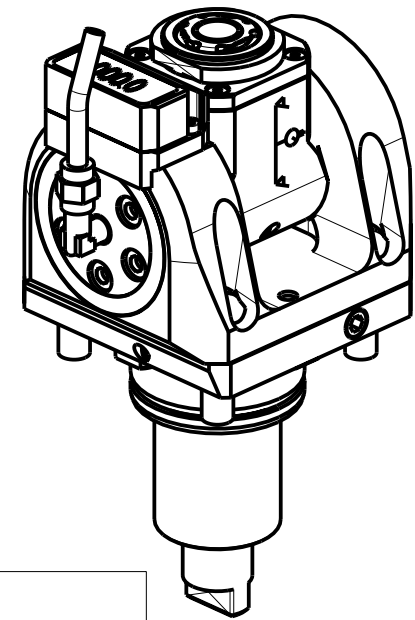

Cod. MT	Mandrino Spindle Spindel	I	RPM	Coppia Max Max Torque Max Drehmoment	Reversibile lato mandrino/contromandrino Reversible sub/main spindle side Umkehrbare Spindelsete/Gegenspindelsete	Lubrificazione int. Coolant through Innenkuehlung	Lubrificazione est. Ext. coolant Aussenkuehlung	CHIAVI INCLUSE Keys included Schluessel inbegriffen			
								CHUB22	CHUB36	CHTAER20ZC	CHESL07
DW00665120	ERA20	1:1	6000	30Nm	X	-	X	CHUB22	CHUB36	CHTAER20ZC	CHESL07
DW00665220	ERA20	1:1	6000	30Nm	X	P=70bar	X	CHUB22	CHUB36	CHTAER20ZC	CHESL07

HARD INGE
 MOD: T-51/65 12ST. (BMT55)

MODULO MOTORIZZATO ORIENTABILE $\pm 90^\circ$ CON NONIO DIGITALE H=47.5mm
 $\pm 90^\circ$ adjustable angle driven tool with digital display H=47.5mm
 Angetriebenes Werkzeug schwenkbar $\pm 90^\circ$ mit digital display H=47.5mm

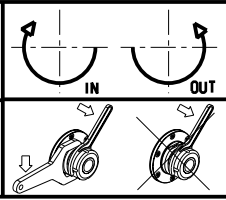

M.T. srl
 Via Casino Albini 480
 Tel. 0541/956034-957884
 Fax 0541/956341
 47842 S. GIOVANNI IN M. (RN)
 e-mail: mtma@mtmarchetti.com
 http://www.mtmarchetti.com



PAGINA HRD335-2-01

Subject to change without notice.