

ATTENZIONE - ATTENTION - ACHTUNG

- Per lo smontaggio degli utensili utilizzare sempre la chiave di contrasto come indicato nel manuale d'uso.
- For disassembly of the tools use always the contrast key as mentioned in the user instructions.
- Fuer das Abmontieren der Werkzeuge immer den Gegenschlüssel benutzen wie in der Bedienungsanleitung erwaeht.

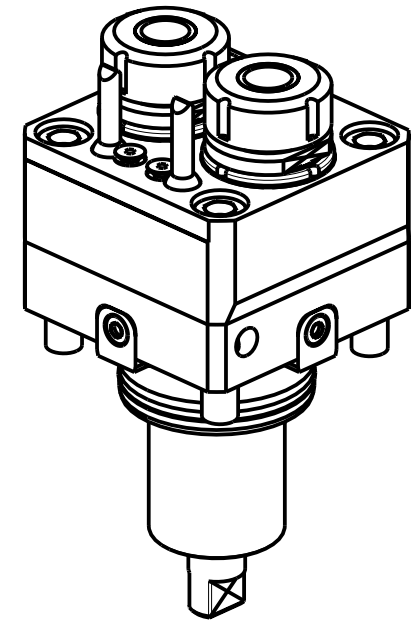

Cod. MT	Mandrino Spindle Spindel	I	RPM	Coppia Max Max Torque Max Drehmoment	Lubrificazione est. Ext. coolant Aussehenkuehlung	A	CHIAVI NON INCLUSE Keys not included Schlüssel nicht einbegriffen	
DW 00540216	ER16	1:1	6000	30Nm	X	84.5	CHMNER16	CHUB17
DW 00540225	ER25	1:1	6000	30Nm	X	85	CHSTER25	MNLO210007

DN SOLUTIONS (DOOSAN) BMT 65

MOD: TT2000SY-TT2500SY-TT2500MS - PUMA 2100-2600M/MS/Y/SY (BMT65) - PUMA 3100 M/Y

MODULO MOTORIZZATO RADIALE 2 USCITE IN Y

Radial single side twin head driven tool in Y

Radial angetriebenes Werkzeug 2 Ausgaenge in Y

Subject to change without notice.

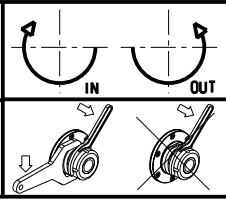

M.T. srl
 Via Casino Albini 480
 Tel. 0541/956034-957884
 Fax 0541/956341
 47842 S. GIOVANNI IN M. (RN)
 e-mail: mtma@mtmarchetti.com
 http://www.mtmarchetti.com



PAGINA DW 0080-3-00