

**ATTENZIONE - ATTENTION - ACHTUNG**

- VERIFICARE LE MISURE DI INGOMBRO PER POSSIBILE INTERFERENZA SU ALCUNI MODELLI DI MACCHINE
- Please check the overall sizes for possible interferences on some machine models
- Bitte überprüfen sie das ausmass um mögliche interferenzen auf einigen maschinen modellen zu vermeiden

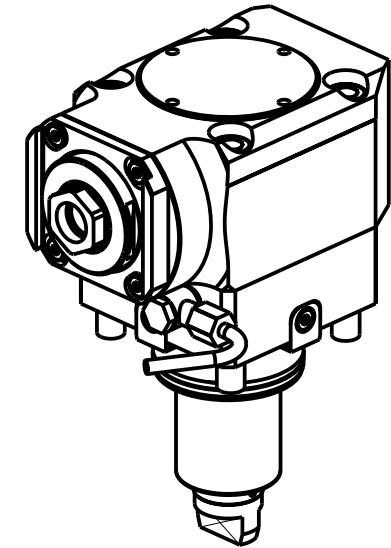
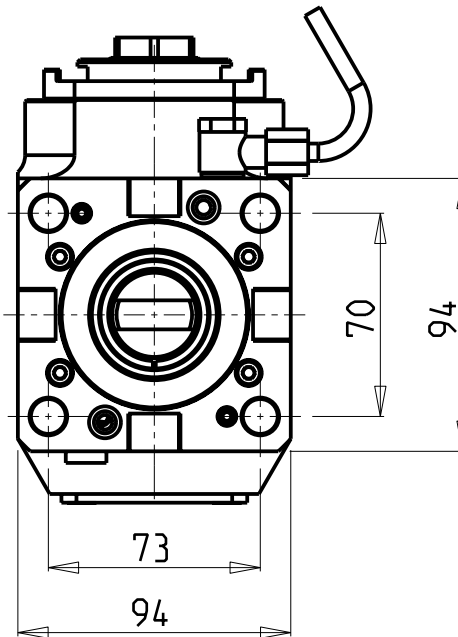
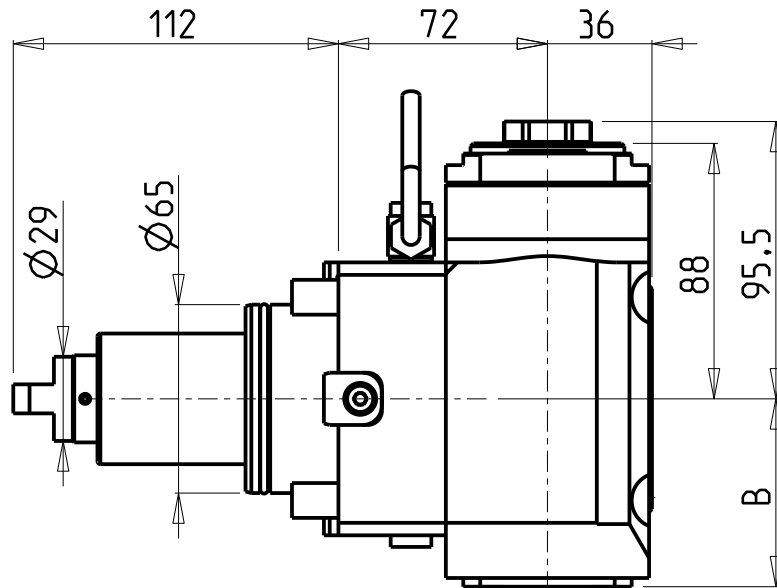

- Chiave inclusa
- Key included
- Schluessel inbegriffen

Cod. MT	Mandrino Spindle Spindel	I	RPM	Coppia Max Max Torque Max Drehmoment	Reversibile lato mandrino/contromandrino Reversible sub/main spindle side Umkehrbare Spindel-seite/ Gegenspindel-seite	Lubrificazione int. Coolant through Innenkuehlung	Lubrificazione est. Ext. coolant Aussenkuehlung	B	CHIAVI NON INCLUSE Keys not included Schluessel nicht einbegriffen	
DW 03780125	ER A 25	1:2	12000	30Nm	X	-	X	64.7	OKU0650004	CHUB27
DW 03780225	ER A 25	1:2	12000	30Nm	X	P=70bar	X	73.2	OKU0650004	CHUB27

YCM  
 NT2000-2500 12 STAZIONI  
 MODULO MOTORIZZATO ASSIALE MOLTIPLICATO I=1:2 H=72mm  
 Axial geared-up I=1:2 driven tool H=72mm  
 Axial angetriebenes Werkzeug uebersetzt I=1:2 H=72mm

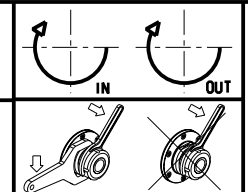

**M.T. srl**  
 Via Casino Albini 480  
 Tel. 0541/956034-957884  
 Fax 0541/956341  
 47842 S. GIOVANNI IN M. (RN)  
 e-mail: mtma@mtmarchetti.com  
 http://www.mtmarchetti.com



PAGINA YCM200-2-10

Subject to change without notice.