

ATTENZIONE - ATTENTION - ACHTUNG

- VERIFICARE LE MISURE DI INGOMBRO PER POSSIBILE INTERFERENZA SU ALCUNI MODELLI DI MACCHINE
- Please check the overall sizes for possible interferences on some machine models
- Bitte überprüfen sie das ausmass um mögliche interferenzen auf einigen maschinen modellen zu vermeiden

ATTENZIONE - ATTENTION - ACHTUNG

- Per lo smontaggio degli utensili utilizzare sempre la chiave di contrasto come indicato nel manuale d'uso.
- For disassembly of the tools use always the contrast key as mentioned in the user instructions.
- Für das Abmontieren der Werkzeuge immer den Gegenschlüssel benutzen wie in der Bedienungsanleitung erwähnt.

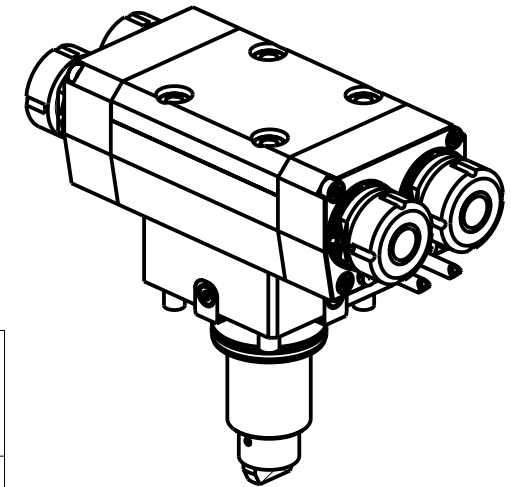

Cod. MT	Mandrino Spindle Spindel	I	RPM	Coppia Max Max Torque Max Drehmoment	Reversibile lato mandrino/contromandrino Reversible sub/main spindle side Umkehrbare Spindel-seite/ Gegenspindel-seite	N°Utensili N°Tools N°Werkzeuge	Lubrificazione est. Ext. coolant Aussenkuehlung	A	B	CHIAVI NON INCLUSE Keys not included Schluessel nicht einbegriffen	
DW 02400416	ER16+ER16	1:1	6000	50Nm	X	2+2	X	114.7	120.7	CHUB17	CHMNER16
DW 02400425	ER25+ER25	1:1	6000	50Nm	X	2+2	X	115.6	121.6	CHUB36	CHSTER25

VICTOR

MOD: VTURN-A16/A20 CM/SCM/YCM/YSCM - VTURN-Q200

MODULO MOTORIZZATO ASSIALE 2+2 USCITE IN Y H=70mm

Axial multiple 2+2 outlet driven tool in Y H=70mm

Axial angetriebenes Mehrspindel-Werkzeug 2+2 Ausgaenge in Y H=70mm

Subject to change without notice.

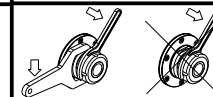

M.T. srl

Via Casino Albini 480
Tel. 0541/956034-957884
Fax 0541/956341
47842 S. GIOVANNI IN M. (RN)
e-mail: mtma@mtmarchetti.com
http://www.mtmarchetti.com

PRODUZIONE MODULI ROTANTI



PAGINA VCT268-1-20