

versione dx
right version
version rechts

versione sx
left version
version links

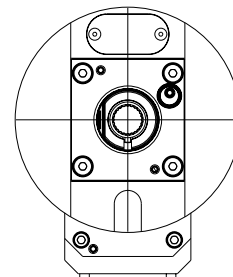
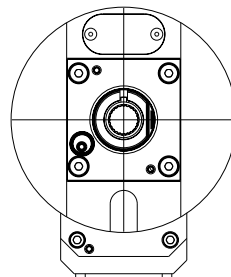

ATTENZIONE - ATTENTION - ACHTUNG

- VERIFICARE LE MISURE DI INGOMBRO PER POSSIBILE INTERFERENZA SU ALCUNI MODELLI DI MACCHINE
- Please check the overall sizes for possible interferences on some machine models
- Bitte überprüfen sie das ausmass um mögliche interferenzen auf einigen maschinen modellen zu vermeiden

-LA FUNZIONE DI POLIGONATURA/DENTATURA DEVE ESSERE INSTALLATA SULLA MACCHINA
-POLYGON CUTTING/GEAR HOBBING FUNCTION MUST BE INSTALLED ON THE MACHINE
-DIE FUNKTION FÜR POLYGON-BZW.VERZÄHNUNGSFRÄSEN MUSS AUF DER MASCHINE FREIGESCHALTET WERDEN

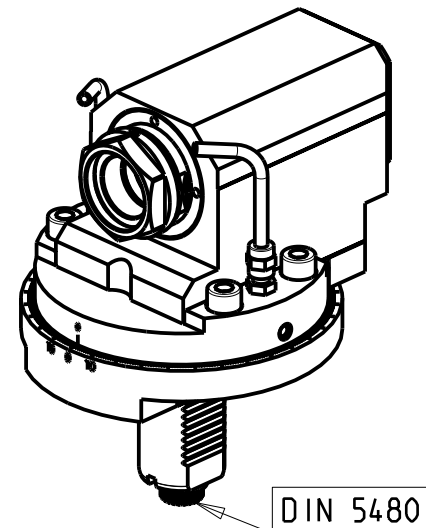
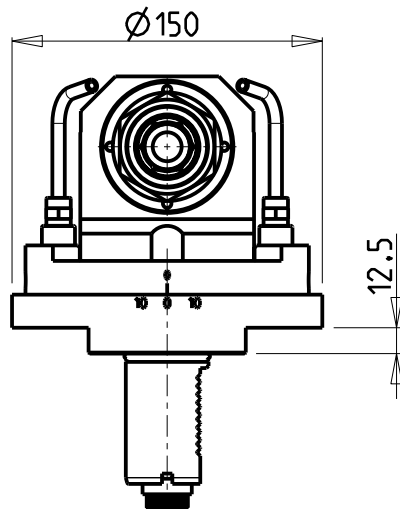
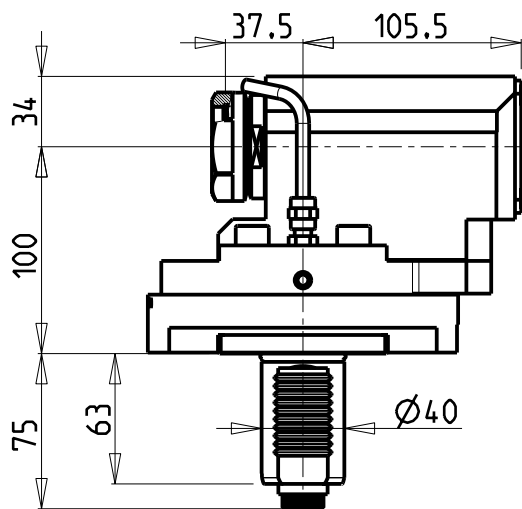

-SOLO PER MACCHINE CON ASSE Y
-ONLY FOR MACHINES WITH Y AXIS
-NUR FÜR MASCHINEN MIT Y-ACHSE

PER PORTAUTENSILI MODULARI MTSK-40 VEDI PAG. TBL300-1-40
FOR MTSK-40 QUIK CHANGE TOOLHOLDERS CLAMPINGS SEE PAGE TBL300-1-40
FUER MTSK-40 MODULARE WERKZEUGAUFNAHMEN SIEHE SEITE TBL300-1-40

Cod. MT		Mandrino Spindle Spindel	I	RPM	Coppia Max Max Torque Max Drehmoment	Lubrificazione est. Ext. coolant Aussehenkuehlung	CHIAVI INCLUSE Keys included Schluessel einbegriffen
versione dx right version version rechts	versione sx left version version links						
SAU0760100	SAU0761100	MTSK-40	1:1	6000	50Nm	X	n°2 CHUB46

SAUTER
VDI 40

MODULO MOTORIZZATO ASSIALE MTSK PER POWER SKIVING H=100mm VDI40 DIN 5480
Axial MTSK driven tool for Power Skiving H=100mm VDI40 DIN 5480
Axial MTSK angetriebenes Werkzeug fuer Power Skiving H=100mm VDI40 DIN 5480

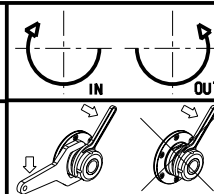

M.T. srl
Via Casino Albini 480
Tel. 0541/956034-957884
Fax 0541/956341
47842 S. GIOVANNI IN M. (RN)
e-mail: mtma@mtmarchetti.com
http://www.mtmarchetti.com



PAGINA SAU350-3-00-K

Subject to change without notice.

09/2023