

ATTENZIONE - ATTENTION - ACHTUNG

- Per lo smontaggio degli utensili utilizzare sempre la chiave di contrasto come indicato nel manuale d'uso.
- For disassembly of the tools use always the contrast key as mentioned in the user instructions.
- Fuer das Abmontieren der Werkzeuge immer den Gegenschlüssel benutzen wie in der Bedienungsanleitung erwäohnt.

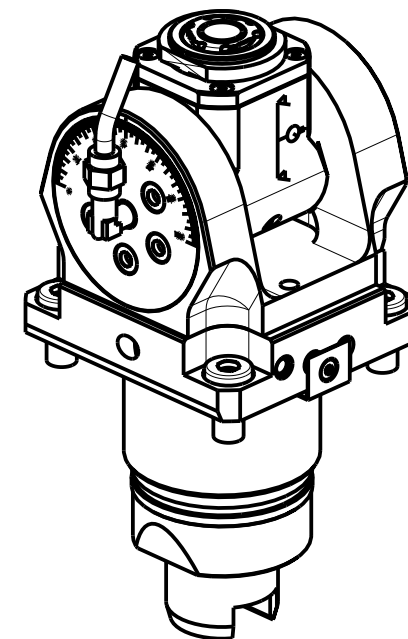

Cod. MT	Mandrino Spindle Spindel	i	RPM	Coppia Max Max Torque Max Drehmoment	Lubrificazione int. Coolant through Innenkuehlung	Lubrificazione est. Ext. coolant Aussenkuehlung	CHIAVI INCLUSE Keys included Schluesssel inbegriffen			
							CHUB22	CHUB36	CHTAER20ZC	CHESLO7
TSM0100120	ERA20	1:1	5000	30Nm	-	X	CHUB22	CHUB36	CHTAER20ZC	CHESLO7
TSM0100220	ERA20	1:1	5000	30Nm	P=70bar	X	CHUB22	CHUB36	CHTAER20ZC	CHESLO7

TSUGAMI
MOD: M06 - M08

MODULO MOTORIZZATO ORIENTABILE +/-90°
+/-90° adjustable angle driven tool
Angetriebenes Werkzeug schwenkbar +/-90°

Subject to change without notice.

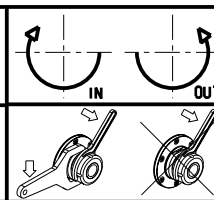

M.T. srl
Via Casino Albini 480
Tel. 0541/956034-957884
Fax 0541/956341
47842 S. GIOVANNI IN M. (RN)
e-mail: mtma@mtmarchetti.com
http://www.mtmarchetti.com



PAGINA TSM335-3-00