

### ATTENZIONE - ATTENTION - ACHTUNG

- Per lo smontaggio degli utensili utilizzare sempre la chiave di contrasto come indicato nel manuale d'uso.
- For disassembly of the tools use always the contrast key as mentioned in the user instructions.
- Fuer das Abmontieren der Werkzeuge immer den Gegenschlüssel benutzen wie in der Bedienungsanleitung erwäehnt.

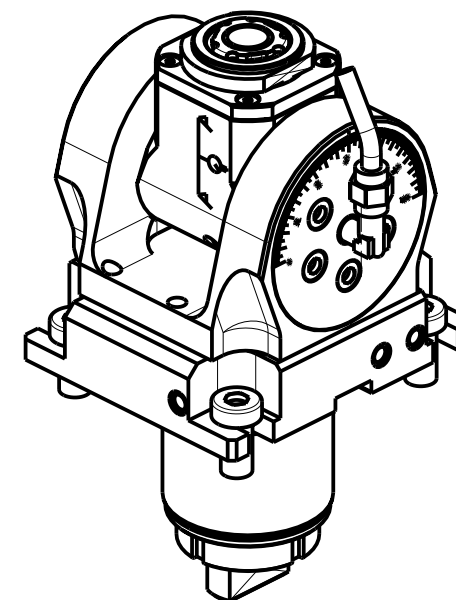

Cod. MT	Mandrino Spindle Spindel	I	RPM	Coppia Max Max Torque Max Drehmoment	Lubrificazione int. Coolant through Innenkuehlung	Lubrificazione est. Ext. coolant Aussenkuehlung	CHIAVI INCLUSE Keys included Schluesssel inbegriffen			
TKW 0330120	ERA20	1:1	6000	30Nm	-	X	CHUB36	CHUB22	CHTAER20ZC	CHESL07
TKW 0330220	ERA20	1:1	6000	30Nm	P=70bar	X	CHUB36	CHUB22	CHTAER20ZC	CHESL07

TAKISAWA  
MOD: TS3000/4000/5000 Y/YS 15 ST. - TM4000 12ST.

MODULO MOTORIZZATO ORIENTABILE +/-90°  
+/-90° adjustable angle driven tool  
Angetriebenes Werkzeug schwenkbar +/-90°

Subject to change without notice.

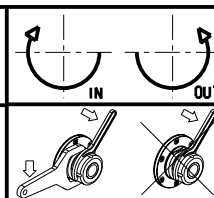

**M.T. srl**

Via Casino Albini 480  
Tel. 0541/956034-957884  
Fax 0541/956341  
47842 S. GIOVANNI IN M. (RN)  
e-mail: mtma@mtmarchetti.com  
http://www.mtmarchetti.com



PAGINA TKW 335-6-00