

ATTENZIONE - ATTENTION - ACHTUNG

- Per lo smontaggio degli utensili utilizzare sempre la chiave di contrasto come indicato nel manuale d'uso.
- For disassembly of the tools use always the contrast key as mentioned in the user instructions.
- Fuer das Abmontieren der Werkzeuge immer den Gegenschlüssel benutzen wie in der Bedienungsanleitung erwaeht.

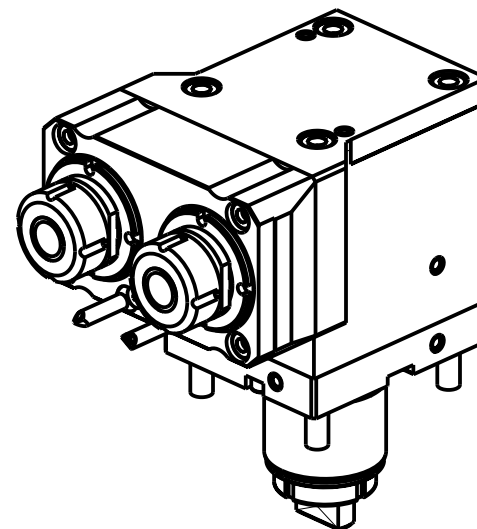

Cod. MT	Mandrino Spindle Spindel	I	RPM	Coppia Max Max Torque Max Drehmoment	Reversibile lato mandrino/contromandrino Reversible sub/main spindle side Umkehrbare Spindel-seite/ Gegenspindel-seite	Lubr.esterna Ext. coolant Aussenkuehlung	A	CHIAVI NON INCLUSE Keys not included Schluesssel nicht einbegriffen		
TKW 0530225	ER25	1:1	6000	40Nm	X	X	137.96	CHUB36	CHSTER25	-
TKW 0530325	ERA25	1:1	6000	40Nm	X	X	126.5	CHUB38	CHUB27	CHTAER25ZC •

- Chiave inclusa
- Key included
- Schluesssel inbegriffen

TAKISAWA
 MOD: TS3000/4000/5000 Y/YS 15 ST. - TM4000 12ST.

MODULO MOTORIZZATO ASSIALE 2 USCITE IN Y
 Axial single side twin head driven tool in Y
 Axial angetriebenes Werkzeug 2 Ausgaenge in Y

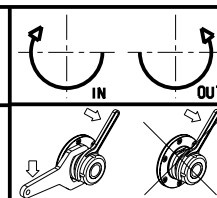

M.T. srl
 Via Casino Albini 480
 Tel. 0541/956034-957884
 Fax 0541/956341
 47842 S. GIOVANNI IN M. (RN)
 e-mail: mtma@mtmarchetti.com
 http://www.mtmarchetti.com



PAGINA TKW 260-6-10

Subject to change without notice.

09/2023