

- Chiave inclusa
- Key included
- Schlüssel inbegriffen

ATTENZIONE - ATTENTION - ACHTUNG

- Per lo smontaggio degli utensili utilizzare sempre la chiave di contrasto come indicato nel manuale d'uso.
- For disassembly of the tools use always the contrast key as mentioned in the user instructions.
- Fuer das Abmontieren der Werkzeuge immer den Gegenschlüssel benutzen wie in der Bedienungsanleitung erwaeht.

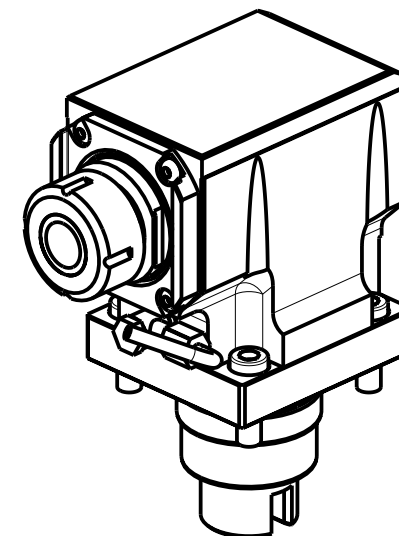

Cod. MT	Mandrino Spindle Spindel	I	RPM	Coppia Max Max Torque Max Drehmoment	Lubr.interna Coolant through Innenkuehlung	Lubr.esterna Ext. coolant Aussenkuehlung	A	A1	D	L	B	CHIAVI NON INCLUDE Keys not included Schlüssel nicht inbegriffen	
												CHSTER32	OKU0650004
TKW 0110332	ER32	1:1	6000	65Nm	-	X	108.7	-	-	-	54.5	CHSTER32	OKU0650004
TKW 0110432	ER32	1:1	6000	65Nm	P=70bar	X	108.7	-	-	-	67	CHSTER32	OKU0650004
TKW 0111527	Ø27x21	1:1	6000	65Nm	-	X	-	85	27	21	54.5	CH_VTCROCE_M12	OKU0650004

TAKISAWA

MOD: EX308/310/508/510/708/710/910 - TT350 MC - NEX908/910 - LA250YS 15ST. - FX-800 - MX-800 - EX2000M/Y

MODULO MOTORIZZATO ASSIALE PER CONTROMANDRINO

Axial driven tool for subspindle

Axial angetriebenes Werkzeug fuer Gegenspindel

Subject to change without notice.

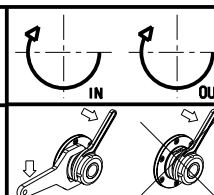

M.T. srl

Via Casino Albini 480
Tel. 0541/956034-957884
Fax 0541/956341
47842 S. GIOVANNI IN M. (RN)
e-mail: mtma@mtmarchetti.com
http://www.mtmarchetti.com



PAGINA TKW 155-2-10