

**ATTENZIONE - ATTENTION - ACHTUNG**

- Con l'utensile orientato a  $\pm 90^\circ$ , non è possibile eseguire lavorazioni a centro-pezzo.
- It is not possible to make machining operations at the center of the part with the tool oriented at  $\pm 90^\circ$ .
- Mit einem Werkzeug  $\pm 90^\circ$  orientiert, ist es nicht möglich, Verarbeitungen an der Werkzeug-Mitte auszuführen.

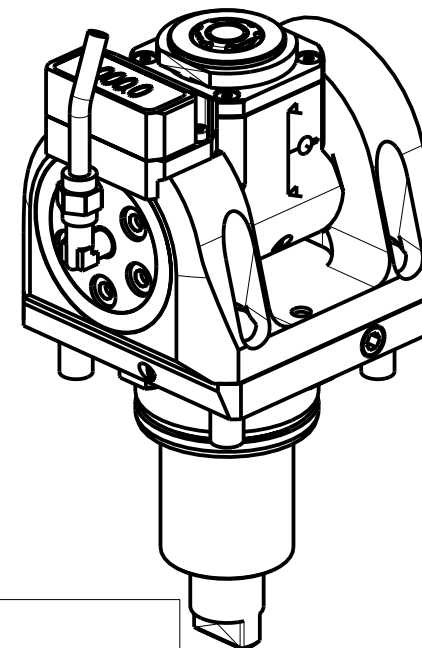

Cod. MT	Mandrino Spindle Spindel	I	RPM	Coppia Max Max Torque Max Drehmoment	Reversibile lato mandrino/contromandrino Reversible sub/main spindle side Umkehrbare Spindel-seite/ Gegenspindel-seite	Lubrificazione int. Coolant through Innenkuehlung	Lubrificazione est. Ext. coolant Aussenkuehlung	CHIAVI INCLUSE Keys included Schluessel inbegriffen			
								CHUB19_SP3	CHUB32	CHTAER16ZC	CHESL07
DW00665316	ERA16	1:2	12000	8Nm	X	-	X	CHUB19_SP3	CHUB32	CHTAER16ZC	CHESL07
DW00665416	ERA16	1:2	12000	8Nm	X	P=70bar	X	CHUB19_SP3	CHUB32	CHTAER16ZC	CHESL07

ROMI  
MOD: GL 300Y/S

MODULO MOTORIZZATO ORIENTABILE  $\pm 90^\circ$  MOLTIPLICATO I=1:2 CON NONIO DIGITALE H=47.5mm  
 $\pm 90^\circ$  adjustable angle driven tool geared-up I=1:2 with digital display H=47.5mm  
 Angetriebenes Werkzeug schwenkbar  $\pm 90^\circ$  uebersetzt I=1:2 mit digital display H=47.5mm

Subject to change without notice.

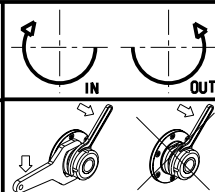

**M.T. srl**  
 Via Casino Albini 480  
 Tel. 0541/956034-957884  
 Fax 0541/956341  
 47842 S. GIOVANNI IN M. (RN)  
 e-mail: mtma@mtmarchetti.com  
 http://www.mtmarchetti.com



PAGINA ROM336-2-01