

ATTENZIONE - ATTENTION - ACHTUNG

- VERIFICARE LE MISURE DI INGOMBRO PER POSSIBILE INTERFERENZA SU ALCUNI MODELLI DI MACCHINE
- Please check the overall sizes for possible interferences on some machine models
- Bitte überprüfen sie das ausmass um mögliche interferenzen auf einigen maschinen modellen zu vermeiden

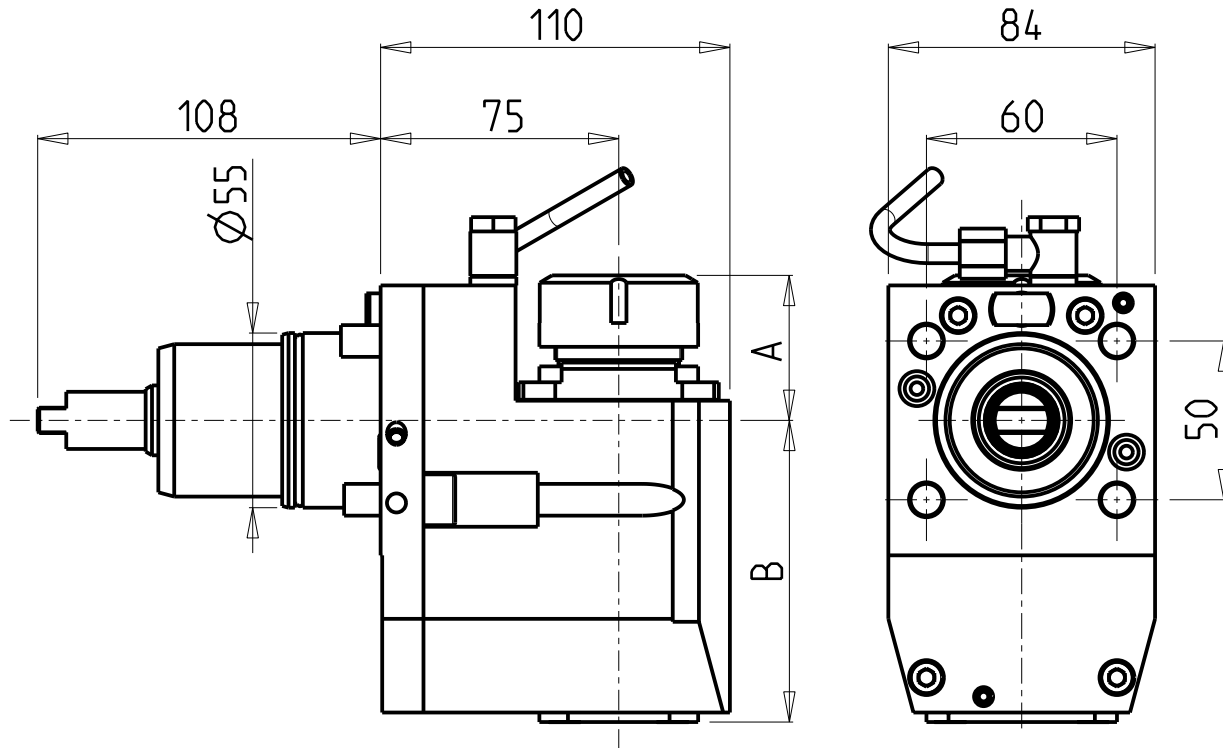
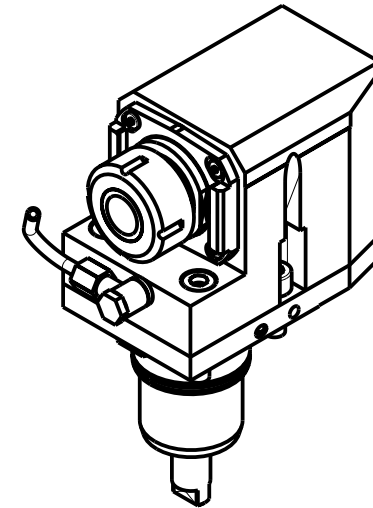

- Chiave inclusa
- Key included
- Schuessel inbegriffen

Cod. MT	Mandrino Spindle Spindel	I	RPM	Coppia Max Max Torque Max Drehmoment	Reversibile lato mandrino/contromandrino Reversible sub/main spindle side Umkehrbare Spindel-seite/ Gegenspindel-seite	Lubr.interna Coolant through Innenkuehlung	Lubrificazione est. Ext. coolant Aussekuehlung	A	B	CHIAVI NON INCLUSE Keys not included Schuessel nicht einbegriffen
NKM1080125	ER25	1:1	6000	50Nm	X	-	X	42.7	95	MNZ0410005 ▪ CHSTER25
NKM1080225	ER25	1:1	6000	50Nm	X	P=70bar	X	42.7	108.5	MNZ0410005 ▪ CHSTER25
NKM1080132	ER32	1:1	6000	50Nm	X	-	X	45.7	95	MNZ0410005 ▪ CHSTER32
NKM1080232	ER32	1:1	6000	50Nm	X	P=70bar	X	45.7	108.5	MNZ0410005 ▪ CHSTER32

NAKAMURA-TOME

WT250 - WT15011/25011 - WTW150 - WTS150 - SC150/200/250 - SC20011 12/16 ST. - SC30011 16ST. - JX200/250 - SUPER NTJX - NTY3 150/250

MODULO MOTORIZZATO ASSIALE ARRETRATO H=75mm
 Axial rear-set driven tool H=75mm
 Axial angetriebenes Werkzeug zurueckversetzt H=75mm

Subject to change without notice.

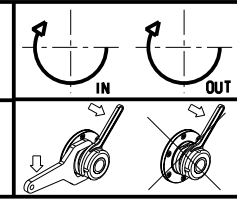

M.T. srl
 Via Casino Albini 480
 Tel. 0541/956034-957884
 Fax 0541/956341
 47842 S. GIOVANNI IN M. (RN)
 e-mail: mtma@mtmarchetti.com
 http://www.mtmarchetti.com



PAGINA NKM180-2-10