

ATTENZIONE - ATTENTION - ACHTUNG

- VERIFICARE LE MISURE DI INGOMBRO PER POSSIBILE INTERFERENZA SU ALCUNI MODELLI DI MACCHINE
- Please check the overall sizes for possible interferences on some machine models
- Bitte überprüfen sie das ausmass um mögliche interferenzen auf einigen maschinen modellen zu vermeiden

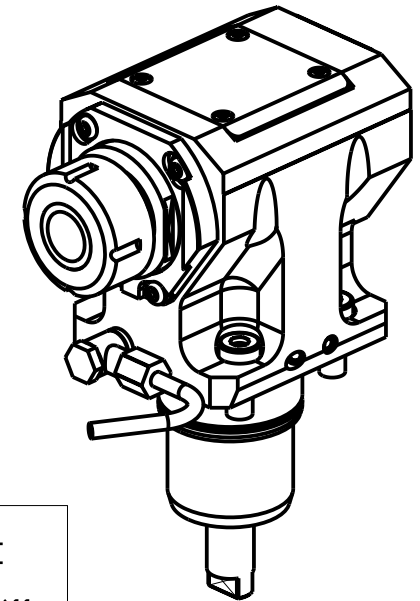

- Chiave inclusa
- Key included
- Schlüssel inbegriffen

Cod. MT	Mandrino Spindle Spindel	I	RPM	Coppia Max Max Torque Max Drehmoment	Reversibile lato mandrino/contromandrino Reversible sub/main spindle side Umkehrbare Spindel-seite/Gegenspindel-seite	Lubr.interna Coolant through Innenkuehlung	Lubr. esterna Ext. coolant Aussenkuehlung	A	B	CHIAVI NON INCLUSE Keys not included Schlüssel nicht einbegriffen	
NKM1390132	ER32	1:1	6000	50Nm	X	-	X	88.7	56.5	CHSTER32	OKU0650004 •
NKM1390140	ER40	1:1	6000	50Nm	X	-	X	99.2	56.5	CHSTER40	OKU0650004 •
NKM1390232	ER32	1:1	6000	50Nm	X	P=70bar	X	88.7	67.5	CHSTER32	OKU0650004 •
NKM1390240	ER40	1:1	6000	50Nm	X	P=70bar	X	99.2	67.5	CHSTER40	OKU0650004 •

NAKAMURA-TOME

WT250 - WT15011/25011 - WTW150 - WTS150 - SC150/200/250 - SC20011 12/16 ST. - SC30011 16ST. - JX200/250
SUPER NTJX - NTY3 150/250 - AS200 15ST.

MODULO MOTORIZZATO ASSIALE H=75mm

Axial driven tool H=75mm

Axial angetriebenes Werkzeug H=75mm

Subject to change without notice.

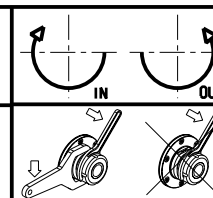

M.T. srl

Via Casino Albini 480
Tel. 0541/956034-957884
Fax 0541/956341
47842 S. GIOVANNI IN M. (RN)
e-mail: mtma@mtmarchetti.com
http://www.mtmarchetti.com



PAGINA NKM150-2-21