

### ATTENZIONE - ATTENTION - ACHTUNG

- VERIFICARE LE MISURE DI INGOMBRO PER POSSIBILE INTERFERENZA SU ALCUNI MODELLI DI MACCHINE
- Please check the overall sizes for possible interferences on some machine models
- Bitte überprüfen sie das ausmass um mögliche interferenzen auf einigen maschinen modellen zu vermeiden

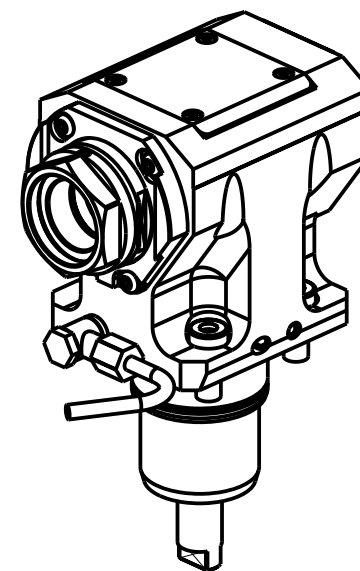

PER PORTAUTENSILI MODULARI MTSK-40 VEDI PAG. TBL300-1-40  
 FOR MTSK-40 QUICK CHANGE TOOLHOLDERS CLAMPINGS SEE PAGE TBL300-1-40  
 FUER MTSK-40 MODULARE WERKZEUGAUFNAHMEN SIEHE SEITE TBL300-1-40

Cod. MT	Mandrino Spindel Spindel	I	RPM	Coppia Max Max Torque Max Drehmoment	Reversibile lato mandrino/contromandrino Reversible sub/main spindle side Umkehrbare Spindel-seite/ Gegenspindel-seite	Lubrificazione int. Coolant through Innenkuehlung	Lubrificazione est. Ext. coolant Aussenkuehlung	B	CHIAVI NON INCLUDE Keys not included Schluessel nicht einbegriffen	
NKM1410140	MTSK-40	1:1	6000	50Nm	X	-	X	56.5	CHUB46	OKU0650004 *
NKM1410240	MTSK-40	1:1	6000	50Nm	X	P=70bar	X	67.5	CHUB46	OKU0650004 *

- Chiave inclusa
- Key included
- Schluessel inbegriffen

### NAKAMURA - TOME

WT250 - WT15011/25011 - WTW150 - WTS150 - SC150/200/250 - SC20011 12/16 ST. - SC30011 16ST. - JX200/250  
 SUPER NTJX - NTY3 150/250 - AS200 15ST.

MODULO MOTORIZZATO ASSIALE MTSK H=75mm

Axial MTSK driven tool H=75mm

Axial MTSK angetriebenes Werkzeug H=75mm

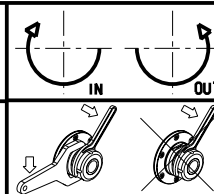

### M.T. srl

Via Casino Albini 480  
 Tel. 0541/956034-957884  
 Fax 0541/956341

47842 S. GIOVANNI IN M. (RN)  
 e-mail: mtma@tmarchetti.com  
 http://www.tmmarchetti.com



PAGINA NKM150-2-21-K

Subject to change without notice.

09/2023