

ATTENZIONE - ATTENTION - ACHTUNG

- Per lo smontaggio degli utensili utilizzare sempre la chiave di contrasto come indicato nel manuale d'uso.
- For disassembly of the tools use always the contrast key as mentioned in the user instructions.
- Fuer das Abmontieren der Werkzeuge immer den Gegenschlüssel benutzen wie in der Bedienungsanleitung erwaeht.

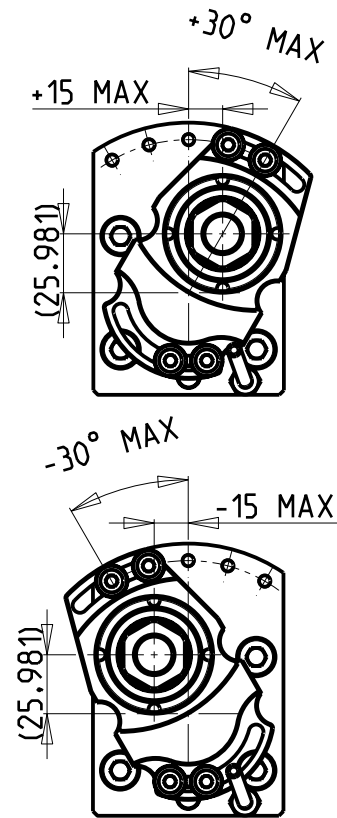

Cod. MT	Mandrino Spindel Spindel	I	RPM	Coppia Max Max Torque Max Drehmoment	Lubrificazione est. Ext. coolant Aussenkuehlung	CHIAVI NON INCLUSE Keys not included Schluessel nicht einbegriffen	
NKM0621025	ERA25	1:1	6000	30Nm	X	CHUB36	CHUB27

NAKAMURA-TOME

WT150/250 - WT15011/25011 - WTW150 - WTS150 - SUPER NTM3 - SUPER NTJ - SUPER NTJX - SC150/200/250 - SC20011 12/16 ST. SC30011 16ST. - JX200/250 - NTY3 150/250 - TW10M/MY/MM/MYY-TW20M/MY/MM/MYY 16ST. - WY 150/250 - AS200 15/12 ST.

MODULO MOTORIZZATO RADIALE ORIENTABILE ±30° DISASSATO 30mm

Radial ±30°adjustable angle driven tool re-directed by 30mm

Radial angetriebenes Werkzeug schwenkbar ±30° achsversetzt um 30mm

Subject to change without notice.

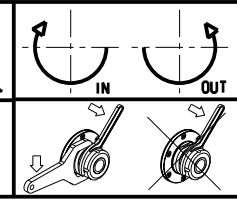

M.T. srl
 Via Casino Albini 480
 Tel. 0541/956034-957884
 Fax 0541/956341
 47842 S. GIOVANNI IN M. (RN)
 e-mail: mtma@mtmarchetti.com
 http://www.mtmarchetti.com



PAGINA NKM135-2-00