

**CUSCINETTI MAGGIORATI  
PER LAVORAZIONI PESANTI**  
Reinforced bearings for  
heavy machining  
Vergroesserte Lager fuer  
schwerere Bearbeitungen

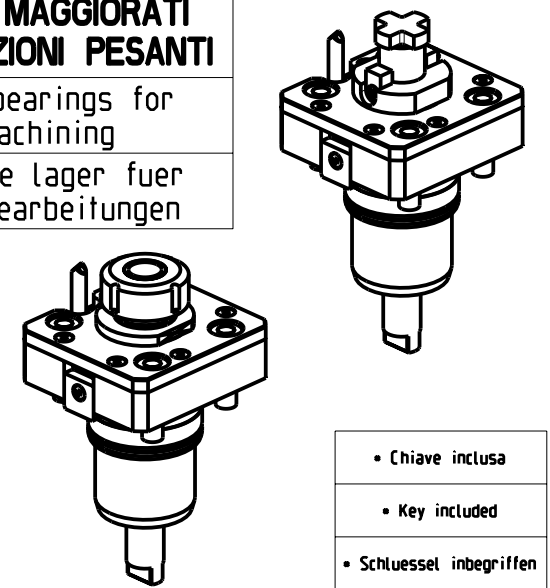

- Chiave inclusa
- Key included
- Schluessel inbegriffen

Cod. MT	Mandrino Spindle Spindel	I	RPM	Coppia Max Max Torque Max Drehmoment	Lubrificazione int. Coolant through Innenkuhlung	Lubrificazione est. Ext. coolant Ausseinkuehlung	A	A1	A2	D	L	CHIAVI NON INCLUDE Keys not included Schluessel nicht einbegriffen		
NKM1830325	ERA25	1:1	6000	50Nm	-	X	50	-	-	-	-	OKU0290009*	CHUB27	-
NKM1830432	ERA32	1:1	6000	50Nm	P=70bar	X	66	-	-	-	-	OKU0290009*	CHTAER32ZC	CHUB30
NKM1830125	ER25	1:1	6000	50Nm	-	X	59.16	-	-	-	-	OKU0290009*	CHSTER25	-
NKM1830225	ER25	1:1	6000	50Nm	P=70bar	X	73.96	-	-	-	-	OKU0290009*	CHSTER25	-
NKM1830132	ER32	1:1	6000	50Nm	-	X	64.96	-	-	-	-	OKU0290009*	CHSTER32	-
NKM1830232	ER32	1:1	6000	50Nm	P=70bar	X	78.46	-	-	-	-	OKU0290009*	CHSTER32	-
NKM1830516	Ø16x17	1:1	6000	50Nm	-	X	-	38	-	16	17	OKU0290009*	CH_VTCROCE_M08	-
NKM1830419	Ø3/4"x3/4"	1:1	6000	50Nm	-	X	-	39	-	3/4"	3/4"	OKU0290009*	CH_VTCROCE_M08	-
NKM1830522	Ø22x19	1:1	6000	50Nm	-	X	-	39	-	22	19	OKU0290009*	CH_VTCROCE_M10	-
NKM0702519	Ø1"x19	1:1	6000	50Nm	-	X	-	42	-	1"	19	CHUB41	CH_VTCROCE_M12	-
NKM0700516	WELDON 16	1:1	6000	50Nm	-	X	-	-	48.5	-	-	-	-	-

**NAKAMURA-TOME**  
WT150/250 - WT15011/25011 - WTW150 - WTS150 - SUPER NTM3 - SUPER NTJ - SUPER NTJX - SC150/200/250 - SC20011 12/16 ST.  
SC30011 16ST. - JX200/250 - NTY3 150/250 - TW10M/MY/MM/MMY/MMYY-TW20M/MY/MM/MMY/MMYY 16ST. - WY 150/250 - AS200 15/12 ST.

**MODULO MOTORIZZATO RADIALE**  
Radial driven tool  
Radial angetriebenes Werkzeug

Subject to change without notice.

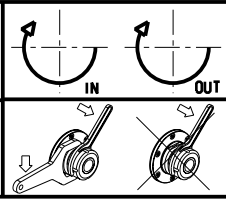

**M.T. srl**  
Via Casino Albini 480  
Tel. 0541/956034-957884  
Fax 0541/956341  
47842 S. GIOVANNI IN M. (RN)  
e-mail: mtma@mtmarchetti.com  
http://www.mtmarchetti.com



PAGINA NKM020-2-00