

ATTENZIONE - ATTENTION - ACHTUNG

- Per lo smontaggio degli utensili utilizzare sempre la chiave di contrasto come indicato nel manuale d'uso.
- For disassembly of the tools use always the contrast key as mentioned in the user instructions.
- Fuer das Abmontieren der Werkzeuge immer den Gegenschlüssel benutzen wie in der Bedienungsanleitung erwaeht.

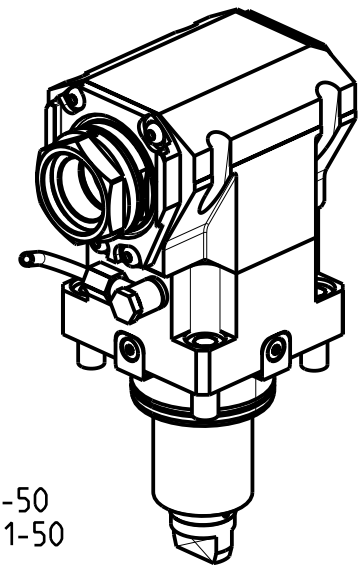

PER PORTAUTENSILI MODULARI MTSK-40 VEDI PAG. TBL300-1-40 E PER MTSK-50 VEDI PAG. TBL300-1-50
 FOR MTSK-40 QUIK CHANGE TOOLHOLDERS CLAMPINGS SEE PAGE TBL300-1-40 AND FOR MTSK-50 SEE PAGE TBL300-1-50
 FUER MTSK-40 MODULARE WERKZEUGAUFNAHMEN SIEHE SEITE TBL300-1-40 UND FUER MTSK-50 SIEHE SEITE TBL300-1-50

Cod. MT	Mandrino Spindle Spindel	I	RPM	Coppia Max Max Torque Max Drehmoment	Reversibile lato mandrino/contromandrino Reversible sub/main spindle side Umkehrbare Spindel-seite/ Gegenspindel-seite	Lubr.interna Coolant through Innenkuehlung	Lubr.esterna Ext. coolant Aussenkuehlung	A	B	CHIAVI NON INCLUSE Keys not included Schluessel nicht einbegriffen
DW 01190140	MTSK-40	1:1	6000	100Nm	X	-	X	77	54	CHUB46 OKU0650004 •
DW 01190240	MTSK-40	1:1	6000	100Nm	X	P=70bar	X	77	65	CHUB46 OKU0650004 •
DW 01190150	MTSK-50	1:1	6000	100Nm	X	-	X	79	54	CHUB55 OKU0650004 •
DW 01190250	MTSK-50	1:1	6000	100Nm	X	P=70bar	X	79	65	CHUB55 OKU0650004 •

- Chiave inclusa
- Key included
- Schluessel inbegriffen

HYUNDAI-W IA (KIA)

SKT200TTM/TTMS/TTSY - LM2000TTM/TTMS/TTSY - L2000/2600/3000Y/SY - L300M/LM/MS/LMS
 SKT250TTM/TTMS/TTSY - LM2500TTM/TTMS/TTSY - SKT250M/LM/MS - SKT300M/LM/MS - SKT-V3RM/LM - LV450RM/LM - HD2600/3100 (BMT65)

MODULO MOTORIZZATO ASSIALE MTSK H=100mm
 Axial MTSK driven tool H=100mm
 Axial MTSK angetriebenes Werkzeug H=100mm

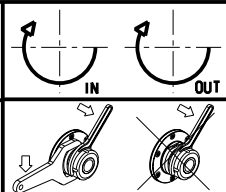

M.T. srl
 Via Casino Albini 480
 Tel. 0541/956034-957884
 Fax 0541/956341
 47842 S. GIOVANNI IN M. (RN)
 e-mail: mtma@tmarchetti.com
 http://www.tmmarchetti.com



PAGINA KIA150-3-21-K

Subject to change without notice.