

### CUSCINETTI MAGGIORATI PER LAVORAZIONI PESANTI

Reinforced bearings for  
heavy machining

Vergroesserte Lager fuer  
schwerere Bearbeitungen

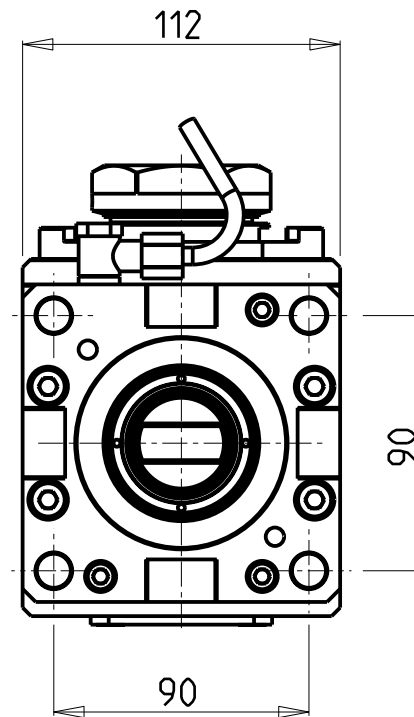
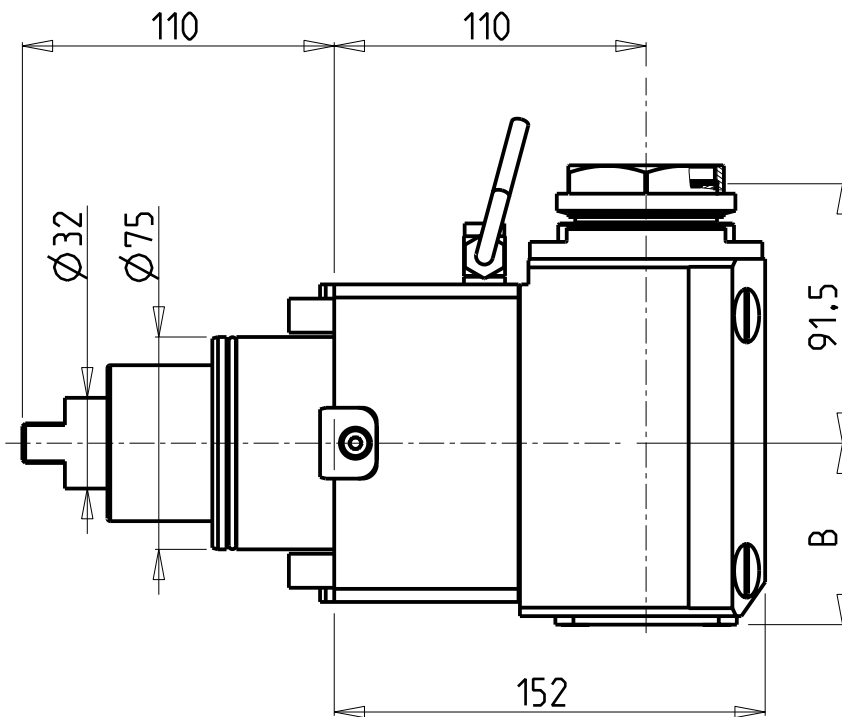
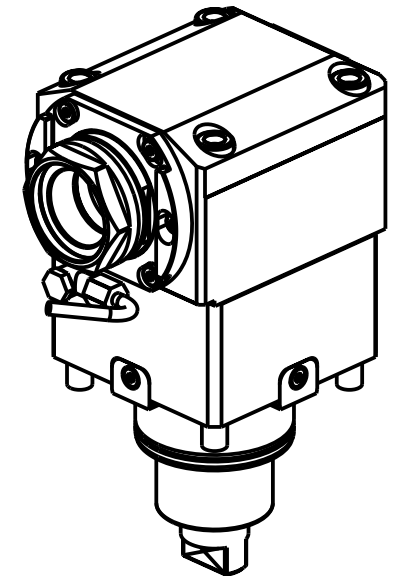

PER PORTAUTENSILI MODULARI MTSK-50 VEDI PAG. TBL300-1-50  
FOR MTSK-50 QUICK CHANGE TOOLHOLDERS CLAMPINGS SEE PAGE TBL300-1-50  
FUER MTSK-50 MODULARE WERKZEUGAUFNAHMEN SIEHE SEITE TBL300-1-50

- Chiave inclusa
- Key included
- Schluessel inbegriffen

Cod. MT	Mandrino Spindel Spindel	I	RPM	Coppia Max Max Torque Max Drehmoment	Reversibile lato mandrino/contromandrino Reversible sub/main spindle side Umkehrbare Spindel-seite/ Gegen-spindel-seite	Lubr.interna Coolant through Innenkuehlung	Lubr.esterna Ext. coolant Aussenkuehlung	B	CHIAVI NON INCLUSE Keys not included Schluessel nicht einbegriffen
DW 02160150	MTSK-50	1:1	6000	140Nm	X	-	X	64	CHUB55 OKU04 30007 ▪
DW 02160250	MTSK-50	1:1	6000	140Nm	X	P=70bar	X	76.5	CHUB55 OKU04 30007 ▪

#### HW ACHEON

HI-TECH 550 - HI-TECH 700 MC (BMT75) - VT550/650 MC

MODULO MOTORIZZATO ASSIALE MAGGIORATO MTSK H=110mm

Axial MTSK reinforced driven tool H=110mm

Axial MTSK angetriebenes Werkzeug vergroessert H=110mm

Subject to change without notice.

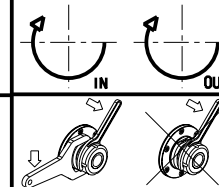

#### M.T. srl

Via Casino Albini 480  
Tel. 0541/956034-957884  
Fax 0541/956341  
47842 S. GIOVANNI IN M. (RN)  
e-mail: mtma@mtmarchetti.com  
http://www.mtmarchetti.com



PAGINA HWC170-3-30-K