

ATTENZIONE - ATTENTION - ACHTUNG

- VERIFICARE LE MISURE DI INGOMBRO PER POSSIBILE INTERFERENZA SU ALCUNI MODELLI DI MACCHINE
- Please check the overall sizes for possible interferences on some machine models
- Bitte überprüfen sie das ausmass um mögliche interferenzen auf einigen maschinen modellen zu vermeiden

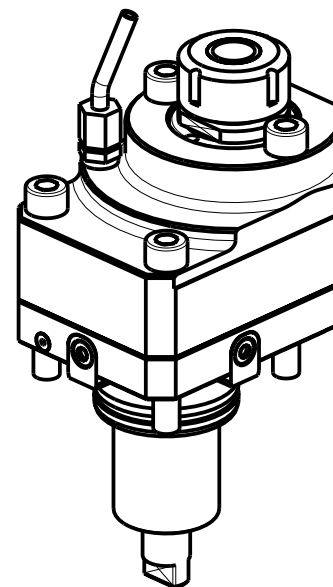

- Chiave inclusa
- Key included
- Schluessel inbegriffen

Cod. MT	Mandrino Spindle Spindel	I	RPM	Coppia Max Max Torque Max Drehmoment	Reversibile lato mandrino/contromandrino Reversible sub/main spindle side Umkehrbare Spindel-seite/ Gegenspindel-seite	Lubrificazione int. Coolant through Innenkuehlung	Lubrificazione est. Ext. coolant Ausssenkuehlung	A	B	A1	D	L	CHIAVI NON INCLUSE Keys not included Schluessel nicht einbegriffen	
0720025	ER25	1:1	6000	50Nm	X	-	X	106.86	20	-	-	-	CHSTER25	MNL0210007
0720032	ER32	1:1	6000	50Nm	X	-	X	120.56	20	-	-	-	CHSTER32	MNL0210007
DW 02710420	ERA20	1:1	6000	50Nm	X	P=70bar	X	94.5	29	-	-	-	CHTAER20ZC	MNL0210007
0720016	Ø16x17	1:1	6000	50Nm	X	-	X	-	20	88.5	16	17	CH_VTCROCE_M08	MNL0210007
0720022	Ø22x19	1:1	6000	50Nm	X	-	X	-	20	90.5	22	19	CH_VTCROCE_M10	MNL0210007
0720027	Ø27x21	1:1	6000	50Nm	X	-	X	-	20	92.5	27	21	CH_VTCROCE_M12	MNL0210007

HW ACHEON
CUTEX 160/180

MODULO MOTORIZZATO RADIALE DISASSATO IN Z 36mm
Radial driven tool re-directed in Z by 36mm
Radial angetriebenes Werkzeug achsversetzt in Z um 36mm

Subject to change without notice.

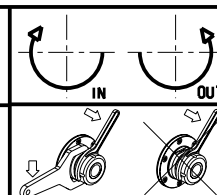

M.T. srl
Via Casino Albini 480
Tel. 0541/956034-957884
Fax 0541/956341
47842 S. GIOVANNI IN M. (RN)
e-mail: mtma@mtmarchetti.com
<http://www.mtmarchetti.com>



PAGINA HWC030-1-10