

### ATTENZIONE - ATTENTION - ACHTUNG

- E' consigliato l'utilizzo su torni dotati di controllo dell'asse Y
- It is recommended to use lathes with the required control of the Y-axis.
- Es ist empfehlenswert Drehbänke, ausgerüstet mit Kontrolle der Y-Achse, zu gebrauchen.

INCLINAZIONE  
REGOLABILE ±15°

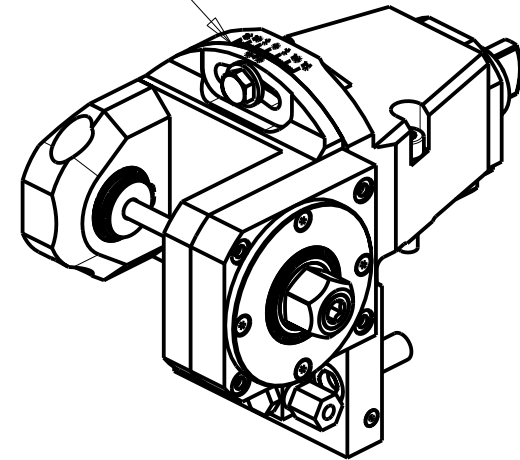

### DOTAZIONI - SUPPLIED WITH - AUSSTATTUNG

- | mm / inch |                             |
|-----------|-----------------------------|
|           | - N°1 ALBERO + DISTANZIALI  |
|           | - N°1 SHAFT + SPACER        |
|           | - N°1 DORN + ABSTANDSSTUECK |

-LA FUNZIONE DI POLIGONATURA/DENTATURA DEVE ESSERE INSTALLATA SULLA MACCHINA  
-POLYGON CUTTING/GEAR HOBBING FUNCTION MUST BE INSTALLED ON THE MACHINE  
-DIE FUNKTION FÜR POLYGON-BZW. VERZÄHNUNGSFRÄSEN MUSS AUF DER MASCHINE FREIGESCHALTET WERDEN

Cod. MT	I	RPM max	Coppia Max Max Torque Max Drehmoment	Lubrificazione est. Ext. coolant Aussenkuehlung	D	CHIAVI INCLUSE Keys included Schlüssel inbegriffen				
						CHUB24	CHUB13	CHESL08	CHESL04	
M0311108	1:1	6000	50Nm	X	8	CHUB24	CHUB13	CHESL08	CHESL04	
M0311110	1:1	6000	50Nm	X	10	CHUB24	CHUB17	CHUB13	CHESL08	CHESL05
M0311113	1:1	6000	50Nm	X	13	CHUB24	CHUB19	CHUB13	CHESL08	CHESL06
M0311116	1:1	6000	50Nm	X	16	CHUB24	CHUB13	CHESL08		

GOODWAY

MOD: GS200/230/260/280 - GA200/260/280 - GA2000/2600/2800/3000/3300/3600

MODULO MOTORIZZATO PORTACREATORE RADIALE

Radial driven gear hobber

Radial angetriebenes Zahnradwaelzfraes-Werkzeug

Subject to change without notice.

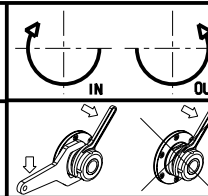

**M.T. srl**

Via Casino Albini 480  
Tel. 0541/956034-957884

Fax 0541/956341

47842 S. GIOVANNI IN M. (RN)  
e-mail: mtma@mtmarchetti.com  
http://www.mtmarchetti.com



PAGINA GDW 340-2-30

09/2023