

-COMPATIBILE CON UTENSILI COMMERCIALI AD INSERTI
 -COMPATIBLE WITH COMMERCIAL INSERT CUTTING-TOOLS
 -KOMPATIBEL MIT HANDELSÜBLICHEN SCHNEIDWERKZEUGEN

ATTENZIONE - ATTENTION - ACHTUNG

- VERIFICARE LE MISURE DI INGOMBRO PER POSSIBILE INTERFERENZA SU ALCUNI MODELLI DI MACCHINE
- Please check the overall sizes for possible interferences on some machine models
- Bitte überprüfen sie das ausmass um mögliche interferenzen auf einigen maschinen modellen zu vermeiden

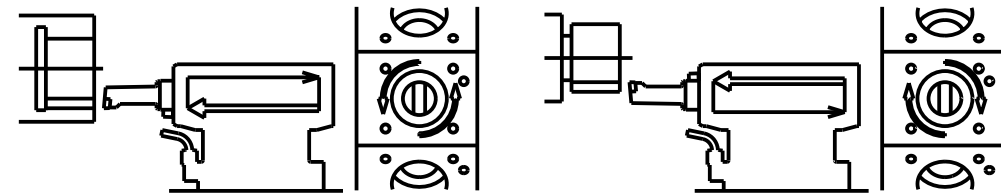
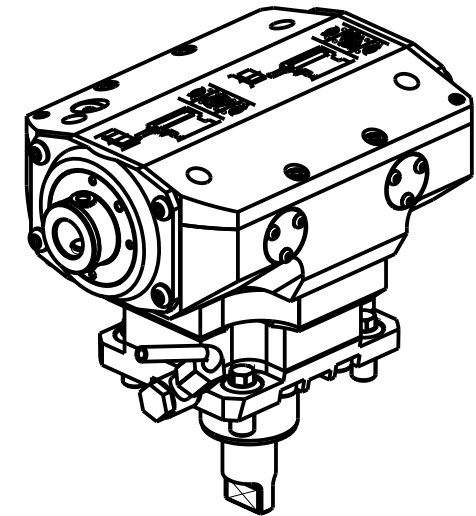
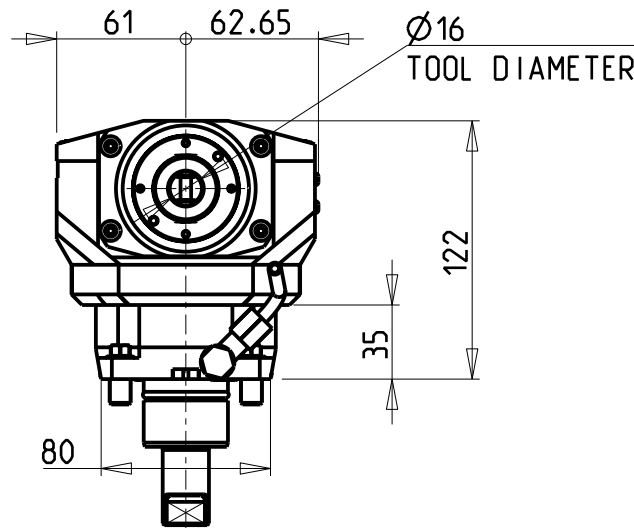
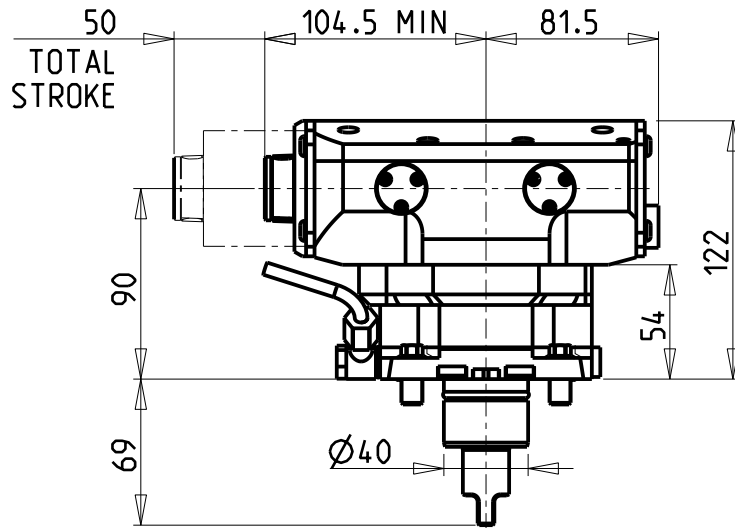
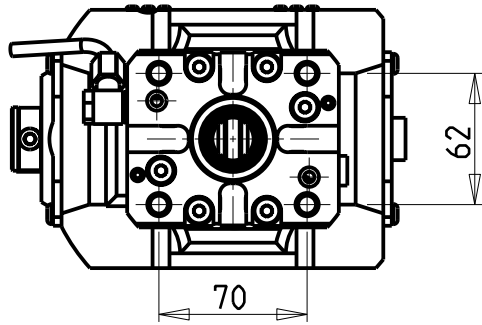

Cod. MT	I	RPM MAX	Reversibile lato mandrino/contromandrino Reversible sub/main spindle side Umkehrbare Spindelseite/ Gegenspindelseite	Lubr. esterna Ext. coolant Aussenkuehlung
MNZ1010100	1:1	500	X	X

NEW

DMG-MORI

NZ1500/2000 - NZX1500/2000 - NZX2500 (BMT40) - NT3100/3150/3200 - NL1500/2000/2500 20 STAZ. - NLX1500/2000/2500 20 STAZ. - NTX500 (BMT40)
 NTX1000/2000/2500/3000 2ND GEN. 12ST. - DURATURN 2050MC/2550MC - NRX2000 - ALX1500/2000/2500 - ECOTURN 450 (BMT40) - NZ DUE/TRE/QUATTRO (BMT40)

MODULO MOTORIZZATO BROCCIAITORE CORSA 50mm H=90mm
 Driven Broaching Toolholder 50mm stroke H=90mm
 Angetriebenes Nutzenstoßwerkzeug 50mm Hub H=90mm

M.T. srl

Via Casino Albini 480
 Tel. 0541/956034-957884
 Fax 0541/956341
 47842 S. GIOVANNI IN M. (RN)
 e-mail: mtma@mtmarchetti.com
 http://www.mtmarchetti.com



PAGINA MNZ360-1-50

Subject to change without notice.

09/2023