

ATTENZIONE - ATTENTION - ACHTUNG

- Per lo smontaggio degli utensili utilizzare sempre la chiave di contrasto come indicato nel manuale d'uso.
- For disassembly of the tools use always the contrast key as mentioned in the user instructions.
- Fuer das Abmontieren der Werkzeuge immer den Gegenschlüssel benutzen wie in der Bedienungsanleitung erwäehnt.

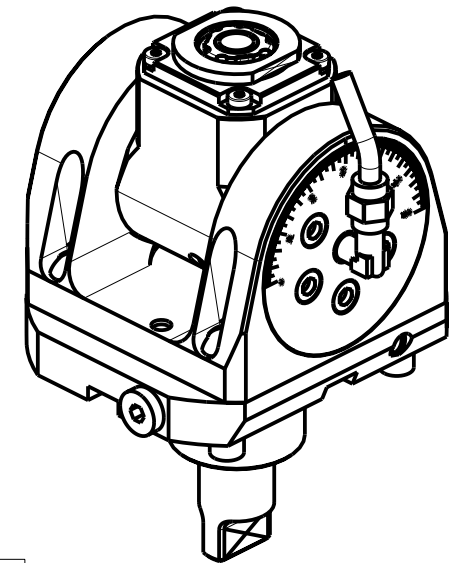

Cod. MT	Mandrino Spindle Spindel	I	RPM	Coppia Max Max Torque Max Drehmoment	Lubrificazione int. Coolant through Innenkuehlung	Lubrificazione est. Ext. coolant Aussenkuehlung	CHIAVI INCLUSE Keys included Schluessel inbegriffen			
							C HUB19_SP3	C HUB32	C HTAER16ZC	C HESL08
MNZ0390316	ERA16	1:2	12000	8Nm		X	C HUB19_SP3	C HUB32	C HTAER16ZC	C HESL08
MNZ0390416	ERA16	1:2	12000	8Nm	P=70bar	X	C HUB19_SP3	C HUB32	C HTAER16ZC	C HESL08

DMG-MORI

NZ1500/2000 - NZX1500/2000 - NZX2500 (BMT40) - NT3100/3150/3200 - NT1000/2000 - NTX1000/2000 - NTX1000/2000/2500/3000 2ND GEN. 12ST. DURATURN 2050MC/2550MC - NRX2000 - ALX1500/2000/2500 - ECOTURN 450 (BMT40)

MODULO MOTORIZZATO ORIENTABILE +/-90° MOLTIPLICATO I=1:2 H=50mm

+/-90° adjustable angle driven tool geared-up I=1:2 H=50mm

Angetriebenes Werkzeug schwenkbar +/-90° uebersetzt I=1:2 H=50mm

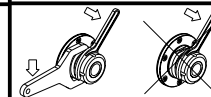

M.T. srl

Via Casino Albini 480
Tel. 0541/956034-957884
Fax 0541/956341
47842 S. GIOVANNI IN M. (RN)
e-mail: mtma@mtmarchetti.com
http://www.mtmarchetti.com



PAGINA MNZ336-1-00

Subject to change without notice.

09/2023