

### ATTENZIONE - ATTENTION - ACHTUNG

- Per lo smontaggio degli utensili utilizzare sempre la chiave di contrasto come indicato nel manuale d'uso.
- For disassembly of the tools use always the contrast key as mentioned in the user instructions.
- Fuer das Abmontieren der Werkzeuge immer den Gegenschlüssel benutzen wie in der Bedienungsanleitung erwäohnt.

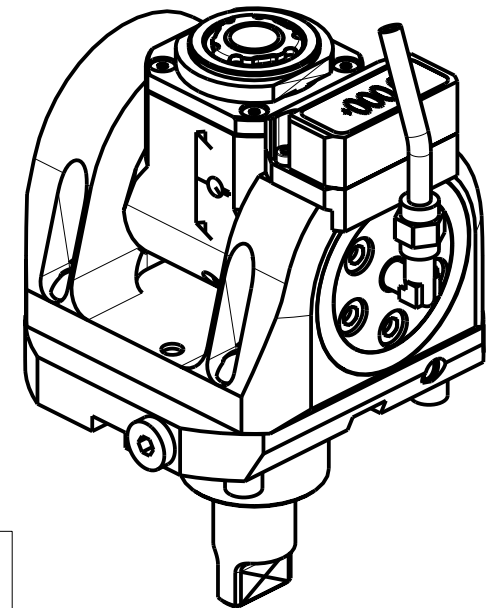

Cod. MT	Mandrino Spindle Spindel	I	RPM	Coppia Max Max Torque Max Drehmoment	Lubrificazione int. Coolant through Innenkuehlung	Lubrificazione est. Ext. coolant Aussenkuehlung	CHIAVI INCLUSE Keys included Schluessel inbegriffen			
MNZ0395120	ER A 20	1:1	6000	30Nm	-	X	CHUB36	CHUB22	CHESLO8	CHTAER20ZC
MNZ0395220	ER A 20	1:1	6000	30Nm	P=70bar	X	CHUB36	CHUB22	CHESLO8	CHTAER20ZC

**DMG-MORI**

NZ1500/2000 - NZX1500/2000 - NZX2500 (BMT40) - NT3100/3150/3200 - NT1000/2000 - NTX1000/2000 - NTX1000/2000/2500/3000 2ND GEN. 12ST. DURATURN 2050MC/2550MC - NRX2000 - ALX1500/2000/2500 - ECOTURN 450 (BMT40)

MODULO MOTORIZZATO ORIENTABILE +/-90° CON NONIO DIGITALE H=50mm

+/-90° adjustable angle driven tool with digital display H=50mm

Angetriebenes Werkzeug schwenkbar +/-90° mit digital display H=50mm

Subject to change without notice.

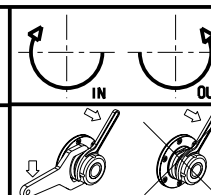

**M.T. srl**

Via Casino Albini 480  
Tel. 0541/956034-957884  
Fax 0541/956341  
47842 S. GIOVANNI IN M. (RN)  
e-mail: mtma@mtmarchetti.com  
<http://www.mtmarchetti.com>



PAGINA MNZ335-1-01