

ATTENZIONE - ATTENTION - ACHTUNG

- Su macchine NZ1500/2000 - NZX1500/2000 - NT3000 SERIE non arriva in centro mandrino.
- On machines NZ1500/2000 - NZX1500/2000 - NT3000 SERIE tool does not get to the centre of the spindle axis.
- Auf Maschinen NZ1500/2000 - NZX1500/2000 - NT3000 SERIE erreicht das Werkzeug nicht die Mitte der Werkzeug-Achse.

ATTENZIONE - ATTENTION - ACHTUNG

- VERIFICARE LE MISURE DI INGOMBRO PER POSSIBILE INTERFERENZA SU ALCUNI MODELLI DI MACCHINE
- Please check the overall sizes for possible interferences on some machine models
- Bitte überprüfen sie das ausmass um mögliche interferenzen auf einigen maschinen modellen zu vermeiden

MNZ0670416

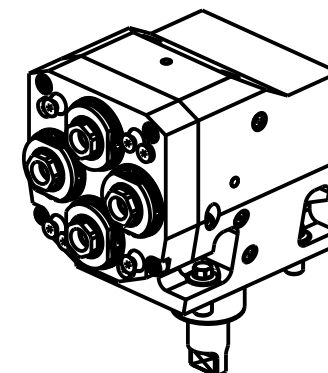
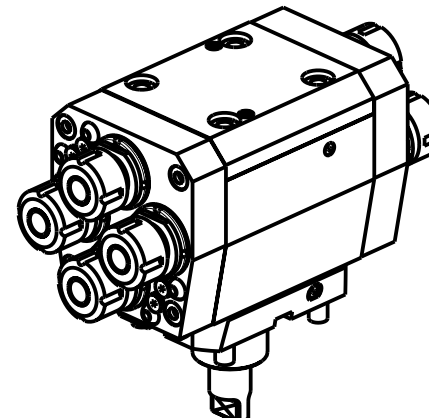
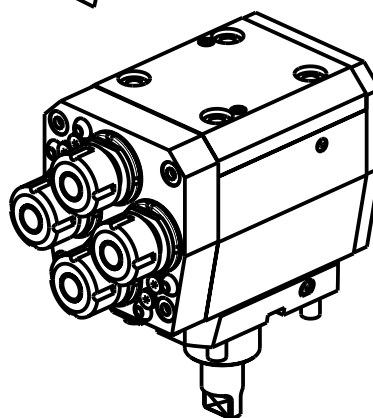

Cod. MT	Mandrino Spindle Spindel	I	RPM	Coppia Max Torque Max Drehmoment	N°Utensili N°Tools N°Werkzeuge	Reversibile lato mandrino/contromandrino Reversible sub/main spindle side Umkehrbare Spindel-seite/ Gegenspindel-seite	Lubr.interna Coolant through Innenkuehlung	Lubr.esterna Ext. coolant Aussenkuehlung	A	B	C	CHIAVI INCLUDE Keys included Schluessel einbegriffen	
MNZ0040116	ERA16	1:1	6000	30Nm	4	X	-	X	96.63	-	79	CHUB32	CHUB19_SP3
MNZ0670416	ERA16	1:1	6000	30Nm	4	X	P=70bar	X	99.07	-	82	CHUB32	CHUB19_SP3
MNZ0040120	ER20	1:1	6000	30Nm	4	X	-	X	113.16	-	79	CHUB32	CHSTER20
MNZ0040216	ERA16+ERA16	1:1	6000	30Nm	4+4	X	-	X	96.63	96.63	79	CHUB32	CHUB19_SP3
MNZ0040220	ER20+ER20	1:1	6000	30Nm	4+4	X	-	X	113.16	113.16	79	CHUB32	CHSTER20

DMG-MORI

NZ1500/2000 - NZX1500/2000 - NT3100/3150/3200 - NL1500/2000/2500 20 STAZ. - NLX1500/2000/2500 20 STAZ.
DURATURN 2050MC/2550MC - ECOTURN 450 (BMT40)

MODULO MOTORIZZATO ASSIALE 4/8 USCITE

Axial multiple 4/8 outlet driven tool

Axial angetriebenes Mehrspindel-Werkzeug 4/8 Ausgaenge

Subject to change without notice.

M.T. srl

Via Casino Albini 480
Tel. 0541/956034-957884
Fax 0541/956341

47842 S. GIOVANNI IN M. (RN)
e-mail: mtma@mtmarchetti.com
http://www.mtmarchetti.com



PAGINA MNZ270-1-00

