

### ATTENZIONE - ATTENTION - ACHTUNG

- VERIFICARE LE MISURE DI INGOMBRO PER POSSIBILE INTERFERENZA SU ALCUNI MODELLI DI MACCHINE
- Please check the overall sizes for possible interferences on some machine models
- Bitte überprüfen sie das ausmass um mögliche interferenzen auf einigen maschinen modellen zu vermeiden

### ATTENZIONE - ATTENTION - ACHTUNG

- Per lo smontaggio degli utensili utilizzare sempre la chiave di contrasto come indicato nel manuale d'uso.
- For disassembly of the tools use always the contrast key as mentioned in the user instructions.
- Fuer das Abmontieren der Werkzeuge immer den Gegenschlüssel benutzen wie in der Bedienungsanleitung erwaeht.

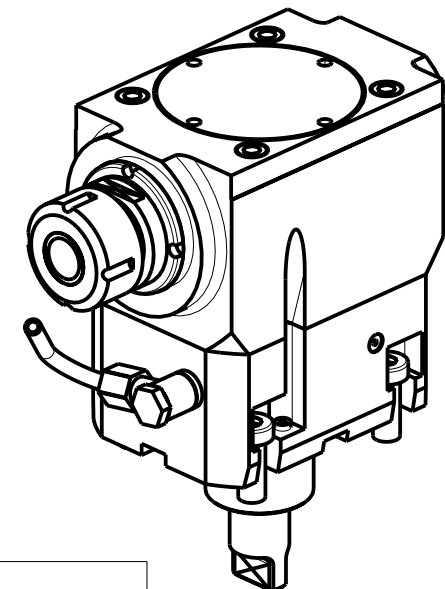

Cod. MT	Mandrino Spindle Spindel	I	RPM	Coppia Max Max Torque Max Drehmoment	Reversibile lato mandrino/contromandrino Reversible sub/main spindle side Umkehrbare Spindel-seite/ Gegenspindel-seite	Lubrificazione int. Coolant through Innenkuehlung	Lubrificazione est. Ext. coolant Aussenkuehlung	B	CHIAVI NON INCLUSE Keys not included Schlüssell nicht einbegriffen	
MNZ0081125	ER25	1:2	12000	30Nm	X		X	67	CHUB36	CHSTER25
MNZ0081225	ER25	1:2	12000	30Nm	X	P=70bar	X	77	CHUB36	CHSTER25

### DMG-MORI

NZ1500/2000 - NZX1500/2000 - NT3100/3150/3200 - NL1500/2000/2500 20 STAZ. - NLX1500/2000/2500 20 STAZ. - NT1000/2000 - NTX500 (BMT40) NTX1000/2000 - NTX1000/2000/2500/3000 2ND GEN. 12ST. - DURATURN 2050MC/2550MC - ALX1500/2000/2500 - NZ DUE/TRE/QUATTRO (BMT40)

MODULO MOTORIZZATO ASSIALE MOLTIPLICATO I=1:2 H=100mm

Axial geared-up I=1:2 driven tool H=100mm

Axial angetriebenes Werkzeug uebersetzt I=1:2 H=100mm

Subject to change without notice.

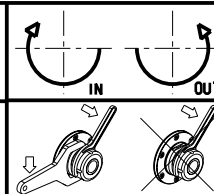

### M.T. srl

Via Casino Albini 480  
Tel. 0541/956034-957884  
Fax 0541/956341

47842 S. GIOVANNI IN M. (RN)  
e-mail: mtma@mtmarchetti.com  
http://www.mtmarchetti.com



PAGINA MNZ200-1-20