

**ATTENZIONE - ATTENTION - ACHTUNG**

- Per lo smontaggio degli utensili utilizzare sempre la chiave di contrasto come indicato nel manuale d'uso.
- For disassembly of the tools use always the contrast key as mentioned in the user instructions.
- Fuer das Abmontieren der Werkzeuge immer den Gegenschlüssel benutzen wie in der Bedienungsanleitung erwäehnt.

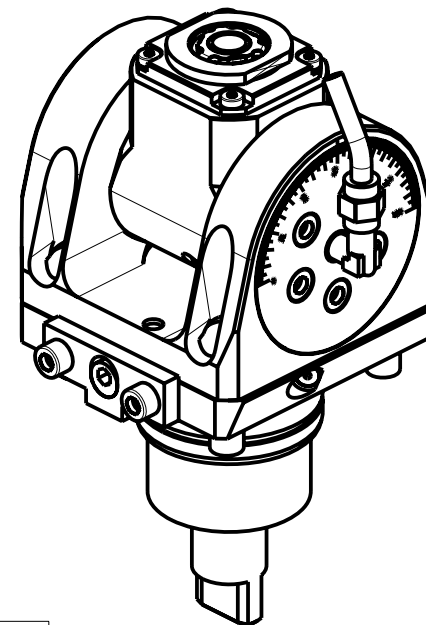

Cod. MT	Mandrino Spindle Spindel	i	RPM	Coppia Max Max Torque Max Drehmoment	Lubrificazione int. Coolant through Innenkuehlung	Lubrificazione est. Ext. coolant Aussenkuehlung	CHIAVI INCLUSE Keys included Schluessel inbegriffen				
							CHUB19	CHUB32	CHTAER16ZC	CHESL07	
BGL0150316	ERA16	1:2	8000	8Nm		X	CHUB19	CHUB32	CHTAER16ZC	CHESL07	NEW
BGL0150416	ERA16	1:2	8000	8Nm	P=70bar	X	CHUB19	CHUB32	CHTAER16ZC	CHESL07	NEW

**BIGLIA**  
 MOD: B301/445/470/501(Y-S)/510/545/550/565/650/658/1200/446/465/745/765

MODULO MOTORIZZATO ORIENTABILE +/-90° MOLTIPLICATO I=1:2  
 Geared-up I=1:2 +/-90° adjustable angle driven tool  
 Angetriebenes Werkzeug schwenkbar +/-90° uebersetzt I=1:2

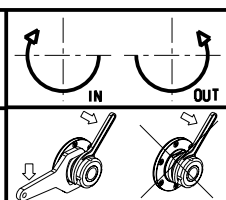

**M.T. srl**  
 Via Casino Albini 480  
 Tel. 0541/956034-957884  
 Fax 0541/956341  
 47842 S. GIOVANNI IN M. (RN)  
 e-mail: mtma@mtmarchetti.com  
 http://www.mtmarchetti.com

PRODUZIONE MODULI ROTANTI

PAGINA BGL336-1-00